



**„POLITEHNICA” UNIVERSITY of BUCHAREST**

**ETTI-B PHD SCHOOL**

**Decision Nr. 480 from 03.12.2019**

# **EXTENDED SUMMARY**

**IOT BEE HIVE MONITORING SYSTEM**

**SISTEM IOT DE MONITORIZARE A FAMILIEI DE  
ALBINE**

Student **Ing. Mihai Vidrașcu**

**PhD Committee**

|                |   |      |  |
|----------------|---|------|--|
| President      | <b>Prof. Dr. Ing. Gheorghe Brezeanu</b>   | from | <b>Politehnica Univ. of Bucharest</b>    |
| PhD Supervisor | <b>Prof. Dr. Ing. Paul Svasta</b>         | from | <b>Politehnica Univ. of Bucharest</b>    |
| Referent       | <b>Prof. Dr. Ing. Dorel Aiordăchioaie</b> | from | <b>Dunărea de Jos Univ. Galați</b>       |
| Referent       | <b>Dr. Ing. Raluca Müller</b>             | from | <b>INCD Microtehnology IMT Bucharest</b> |
| Referent       | <b>Conf. Dr. Ing. Marian Vlădescu</b>     | from | <b>Politehnica Univ. of Bucharest</b>    |

**BUCHAREST 2019**

---



# Table of content

|  |           |
|--|-----------|
| Table of figures .....                               | iii       |
| Table of abbreviations .....                         | v         |
| <b>1. Introduction .....</b>                         | <b>8</b>  |
| 1.1. Thesis context .....                            | 8         |
| 1.2. Thesis purpose .....                            | 9         |
| 1.3. Thesis contents .....                           | 9         |
| <b>2. Bees' life in a nutshell .....</b>             | <b>10</b> |
| 2.1. Colony structure .....                          | 10        |
| 2.2. Short beekeeping calendar .....                 | 11        |
| <b>3. The hive monitor .....</b>                     | <b>13</b> |
| 3.1. System block diagram .....                      | 13        |
| 3.2. The hive monitor power circuits .....           | 14        |
| 3.2.1. The energy source .....                       | 14        |
| 3.2.2. The energy storage device .....               | 14        |
| 3.2.3. The charging circuit .....                    | 15        |
| 3.2.4. The voltage regulator .....                   | 15        |
| 3.3. The sensor interface .....                      | 15        |
| 3.4. The temperature and humidity sensor .....       | 16        |
| 3.5. Weight measurement .....                        | 16        |
| 3.6. Tilt measurement .....                          | 18        |
| 3.7. The microphone .....                            | 18        |
| 3.8. Hive entrance traffic monitoring .....          | 19        |
| 3.9. The radio module and the micro-controller ..... | 19        |

|  |           |
|--|-----------|
| 3.9.1. Component selection .....                             | 20        |
| 3.9.2. Reducing the energy consumption.....                  | 20        |
| <b>4. The data gateway .....</b>                             | <b>21</b> |
| 4.1. The gateway’s architecture .....                        | 21        |
| 4.2. The power circuits.....                                 | 22        |
| <b>5. The hive monitor experimental device .....</b>         | <b>24</b> |
| 5.1. Electronic schematic design .....                       | 24        |
| 5.2. PCB design .....  | 25        |
| 5.3. Software design .....                                   | 26        |
| <b>6. The data gateway experimental device .....</b>         | <b>27</b> |
| 6.1. The prototype assembly .....                            | 27        |
| 6.2. Software design .....                                   | 28        |
| 6.3. The storage and display server .....                    | 28        |
| <b>7. The prototype assembly and hive installation .....</b> | <b>30</b> |
| <b>8. Conclusions .....</b>                                  | <b>32</b> |
| 8.1. Original contributions .....                            | 34        |
| 8.2. Original publications list .....                        | 36        |
| <b>9. Bibliography .....</b>                                 | <b>38</b> |

# Table of figures

|  |    |
|--|----|
| Fig. 3.1 Hive monitoring system schematic diagram .....                                | 13 |
| Fig. 3.2 Power circuit schematic diagram .....   | 14 |
| Fig. 3.13 Power supply prototype [7].....  | 15 |
| Fig. 3.23 SHT21 adapting board .....   | 16 |
| Fig. 3.25 Assembled adapting board .....   | 16 |
| Fig. 3.35 Evaluation board top layer .....   | 17 |
| Fig. 3.36 Evaluation board bottom layer .....  | 17 |
| Fig. 3.38 Weigh scale milling .....  | 17 |
| Fig. 3.39 Assembled weigh scale .....  | 17 |
| Fig. 3.46 The device, ready for a hive.....  | 18 |
| Fig. 3.47 Microphone protection .....  | 18 |
| Fig. 3.57 Hive entrance traffic monitoring prototype .....                             | 19 |
| Fig. 3.62 ESP8266-07 module, with antenna and external antenna<br>connector [12] ..... | 20 |
| Fig. 3.63 ESP8266-12E module with PCB antenna and 4MB flash<br>memory [13] .....       | 20 |
| Fig. 3.64 Module consumption, no optimization: 9s operating<br>time.....               | 20 |
| Fig. 3.71 Complete optimization: 4s operating time .....                               | 20 |
| Fig. 4.6 Gateway block diagram [14] .....  | 22 |
| Fig. 4.7 Two 3kF capacitors, the power converter and the load [14] .....               | 22 |
| Fig. 4.8 ESP8266 as load and recorder [14] .....                                       | 22 |
| Fig. 4.10 LTC3652 test board [14] .....  | 23 |
| Fig. 4.11 Solar panels used for charging tests [14] .....                              | 23 |
| Fig. 5.1 Solar charger electronic schematic .....                                      | 24 |
| Fig. 5.3 Modem and micro-controller module board schematic .....                       | 25 |
| Fig. 5.11 Assembled prototype .....  | 25 |
| Fig. 5.12 The prototype, next to the capacitor .....                                   | 25 |

|   |    |
|---|----|
| Fig. 6.4 TPS63020 converter evaluation design .....                         | 27 |
| Fig. 6.5 Assembled TPS63020 evaluation board.....                           | 27 |
| Fig. 6.6 Gateway circuits, in the enclosure .....                           | 28 |
| Fig. 6.11 Software for data reception, storage and display [15,16,17] ..... | 29 |
| Fig. 7.7 Hive on the scale .....  | 30 |
| Fig. 7.8 Temperature sensor, between the hive bottom and the box .....      | 30 |
| Fig. 7.13 Monitored hive, at winter's end .....                             | 31 |
| Fig. 7.14 Detail: insufficiently protected plywood .....                    | 31 |

# Table of abbreviations

CNC – Computer Numerical Control

EDLC – Electric Double Layer Capacitor

FFT – Fast Fourier Transform

GPRS – Global Packet Radio Service

GSM – Global System for Mobile communication

I2C – Inter-Integrated Circuit

IOT – Internet of Things

MPPC – Maximum Power Point Control

MCU – Micro Controller Unit

MPPT – Maximum Power Point Tracking

MEMS – Micro Electro-Mechanical System

RF – Radio Frequency





# Chapter 1

## Introduction

### 1.1 Thesis context

This thesis describes the introduction of new technologies in one of the oldest human activities: beekeeping. Since ancient times, it relies on beekeeper's skill and experience. He constantly checks the colonies and performs specific activities required at key moments. Many of them are well known today and the activities are relatively easy to schedule.

Work in the apiary is a relaxing pleasure for the ones owning a few colonies. They do not need and do not want help from technology. But everything changes when the owner makes a living out of beekeeping; he needs healthy and strong hives, able of proper production. Any signs of problems going unnoticed (or ignored) by the beekeeper will later become a problem, and fixing takes significantly longer than preventing. It is the case of large apiaries, where it takes a long time to check every hive. Technology can help here, in an attempt to "automate" some of the beekeeper's observation work and to point his attention towards a hive with problems.

By foraging in a 5km area around the hive, bees intercept different polluting agents from the soil, water and air, and become a large coverage "environmental sensor" [1]. A hive fitted with detection instruments can quickly indicate changes in pollution around it. By concentrating the pollutant from such a large surface in a single point, its concentration is amplified, making it easier to detect.

A system that can perform the functions described above is useful both in production, with minimal sensors and in research, where it can be fitted with any imaginable sensor. This project describes the design and practical implementation of a bee hive monitoring system, that can be fitted with various sensors, useful in both production and research. Its main characteristic is the sensor structure flexibility

(useful in research), followed closely by low cost and reliability (required for a production hive).

## **1.2 Thesis purpose**

This project illustrates the author's research and experimental activities, during the PhD studies. It begins with precise requirements, set by professional beekeepers, followed by design and implementation steps. The experimental devices are illustrated in the end, with data gathered during a year from a production hive.

## **1.3 Thesis contents**

The thesis contains eight chapters, each one detailing the relevant research activity, emphasizing the design and the practical implementation of the experimental models.

Chapter 1 is a brief introduction in the context of the thesis domain.

Chapter 2 addresses the honeybee colony structure, its activity and the beekeeper's work, for every month of the year. A technical solution is presented for each of the beekeeper's observation and activity.

Chapter 3 uses data, collected from theory and from practical experience, to construct the system's architecture. Every component of the hive monitor is highly detailed.

Chapter 4 is dedicated to the data gateway design. Its purpose is to link the remote apiary to the mobile data network.

Chapter 5 marks the beginning of the actual device construction, detailing the hive monitor.

Chapter 6 describes the design and partial practical implementation of the data gateway. Hardware and software components are explained, together with a reliable and user-friendly solution for data storage and display.

Chapter 7 details the actual construction of the hive monitor, with a quality level of a commercial product, delivered to a beekeeper for testing.

Chapter 8 presents the conclusions, contributions and the published papers.

The thesis ends with the bibliography, revealing data sources and literature consulted during the research.

# Chapter 2

## Bees' life in a nutshell

The bee is part of one of the most advanced insect groups, Hymenoptera order, Apidae family, Apis kind, mellifera species, also raised in Romania. Social life manifests at this order, as individuals group into a family, working together as a single organism and dividing the hive activities to specific groups of individuals. [2]

### 2.1 Colony structure

The honeybees are associated into families, consisting of three types of individuals: the queen, the worker bees, and the drones. [3]

The queen is the most important individual in a colony, being the only female capable of laying eggs, from which worker bees and drones hatch. It is the only female with completely developed reproductive organs, ensuring the family and species existence.

The drones are the male individuals; a hive has a few hundreds of them. They grow from unfertilized eggs, laid by the queen in larger cells, specifically built by the worker bees on the edge of the combs. [3]

The majority of the family consists of worker bees. They perform all important activities within a hive, gathering, storing and converting nectar and pollen, feeding and caring for the colony's brood, constructing combs, ventilating and cleaning the hive etc. The number of worker bees in a hive is not constant throughout a year and depends on the season and the nectar flow. [3]

The bees work hard during their life, so a worker lives 27-30 days or even less in an intense nectar flow, 40-60 days during spring and autumn and 7-9 months during the cold season. [3]

## 2.2 Short beekeeping calendar

During each season, the beekeeper has several activities to perform. Only the most important ones and the ones enhanceable by technology are reproduced here.

The colony is constantly developing during March and April. The bees that passed the winter are seamlessly replaced by young ones if the hive was properly prepared in the autumn before. The first flowers are blooming and the brood-occupied surface is expanding, as the queen is stimulated to lay eggs by the fresh nectar and pollen. The beekeeper must ensure there is enough space for the brood, without expanding and cooling the nest too much, especially as March has a very changing weather. The colonies are in early preparations for the large nectar flows. He must also provide good conditions for a cleaning flight.

First important nectar flows appear in May: rape and acacia. The weather is very warm, the nests are completely expanded and nectar storage space is required. Special care must be taken to prevent natural swarming.

In June, nature and bees reach their peak in development. Apart from important nectar sources in colder regions, the beekeeper must also deal with linden and sunflower. It is also a good moment to create artificial swarms.

The main nectar flows come to an end on July and August, depending on the region, so the honeybees are reducing their activity. It is the time to begin the winter preparations, by ensuring that the queen keeps laying eggs and the hive population remains large enough. Stimulation food is added in areas with absolutely no nectar flow. It is also a good time to build the winter reserves, so that no more syrup is fed after the first half of September, as it wears down the bees' organisms. The beekeeper must work as carefully as possible, to prevent the pilferage (strong hives attacking and stealing food from the weak ones) in this period.

September's end is dedicated to winter nest preparation and anti-varroa treatments. Keeping the hives warm becomes essential, as temperatures fall below 10°C during the night.

The final autumn months bring lower temperatures and rich rainfall, so the bees are not flying anymore. They keep warm by gathering in shape of a ball, with minimum food consumption, to maintain the nest temperature at a survivable limit.

The colony slowly begins its activity at the end of January. In a small area, the queen starts laying eggs again, and the temperature rises at 34-35°C, as the honey consumption doubles.

The useful parameters for a production hive are weight, sound and internal temperature and humidity. Hive population estimation and a motion sensor are also useful.

All theoretical data is confirmed in practice, by professional beekeepers: Mr. Palaloga from Pălici, Buzău County, Mr. George Teodorescu and Munteanu family from Ordoreanu, Ilfov.

# Chapter 3

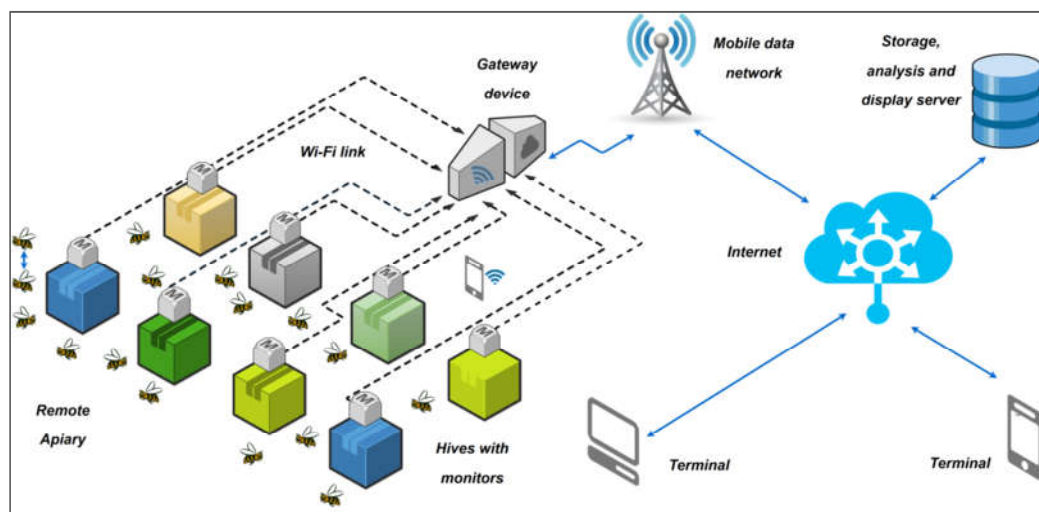
## The hive monitor

The hive will be fitted with a dedicated device, featuring a flexible sensor structure, so the user can easily add and remove sensors, as required. It will be powered by solar energy and installed somewhere under the hive, so that it will not bother the beekeeper during his activities.

### 3.1 System block diagram

The gateway architecture was chosen (illustrated in figure 3.1), keeping in mind the requirements, recommendations and IoT concepts from [4].

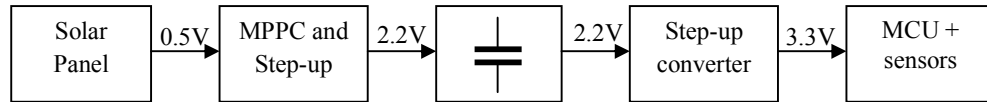
The colonies are equipped with hive monitors, containing solar power circuits, a micro-controller and the configurable sensor structure. At regular intervals, they send the collected data to a single local gateway. Its purpose is to bridge the local WiFi network and the 2G mobile data network. It can also be fitted with a few weather sensors. The final element of the diagram is the storage and display server.



*Fig. 3.1 Hive monitoring system schematic diagram.*

## 3.2 The hive monitor power circuits

To create a maintenance-free system, regular rechargeable batteries are replaced with a super-capacitor. Power comes from a solar panel and the voltage is regulated with a high efficiency step-up converter, with low quiescent current. The final solution is illustrated in figure 3.2.



*Fig. 3.2 Power circuit schematic diagram.*

### 3.2.1 The energy source

The cheapest, most simple way to convert solar energy to electricity is the photovoltaic cell. Small cells were acquired, with 300mA short-circuit current. The cells were assembled with epoxy resin on a glass substrate, to create solar panels, with one or two cells, connected in series. The power output variation with output voltage was experimentally determined, using two cells in series. The maximum power point is located at 0.825V output, with 165mW available power.

### 3.2.2 The energy storage device

Once converted to electricity, the energy must be stored somewhere, with sufficient capacity to keep the system operational for several days of cloudy sky.

Super-capacitors are very reliable passive components, outlasting as charge-discharge cycle count and ruggedness any rechargeable battery on the market today. Low temperature and over-discharge have no side effects; the cycle count reaches in the range of hundreds of thousands. Moreover, they can be charged very fast [6]. Experimentally, it was determined that a 400F capacitor, charged at 2V has a capacity of 126mAh [5].

### 3.2.3 The charging circuit

The first, most important feature of the charger is the ability to operate in the solar panel's maximum power point.

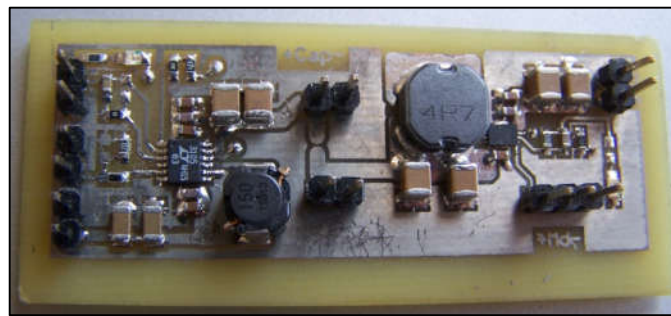
LTC3105 is designed to operate at very low input voltages, coming from high impedance sources. It implements the constant voltage MPPT algorithm. [7]

### 3.2.4 The voltage regulator

The next component in the block schematic is the step-up voltage regulator, providing 3.3V, required by the micro-controller and the sensors. The most important parameter in this application is the very low quiescent current.

LTC3539-1 is a synchronous, 2A step-up converter, with 0.7V start-up voltage and operation down to 0.5V. The active mode power consumption is very low: 10uA. Moreover, the active mode efficiency can reach 94%. Using a 400F capacitor, discharged down to 0.9V, the regulator can extract 824J of energy, at a usable voltage level. [7]

A double-layer prototype was built for testing (figure 3.13).



*Fig. 3.13 Power supply prototype. [7]*

The conclusion of long term testing is that the circuit works best with two solar cells in series.

## 3.3 The sensor interface

Modularity is a design feature of the hive monitor. Easy and fast installation of various sensors, with minimal programming is required. The optimal solution is a common data bus, with addressable sensors.

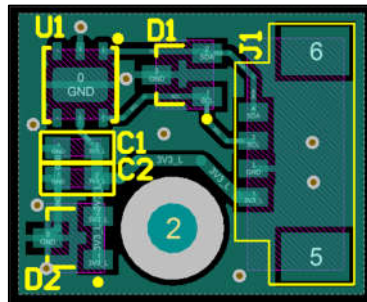


Since there are no special requirements for signaling speed and cable length, the I2C bus is selected. Its simplicity allows connection of up to 128 different devices using only two bidirectional lines.

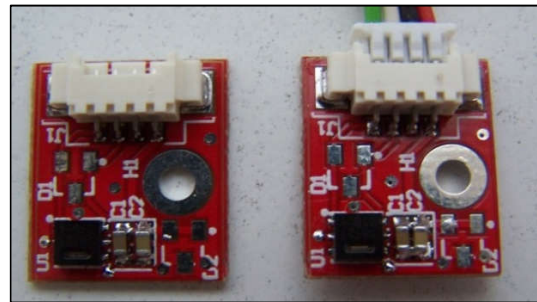
### 3.4 The temperature and humidity sensor

The previous chapter showed the importance of measuring the temperature and humidity inside the hive.

Out of all the sensors on the market, Sensirion's SHT21 was selected. It integrates humidity and temperature transducers and has a low power consumption: 300uA during measurement and 0.15uA in sleep. The carrier board is illustrated in figures 3.23 and 3.25. [10]



*Fig. 3.23 SHT21 adapting board.*



*Fig. 3.25 Assembled adapting board.*

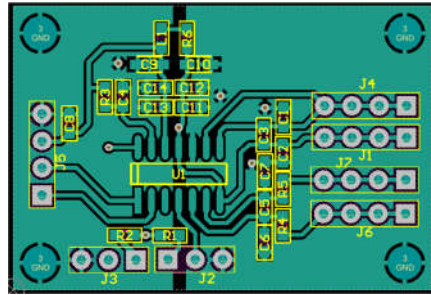
The carrier board is placed on the tip of a long, narrow blade, inserted between the hive bottom and the first box, or between the boxes. The other end of the blade is located outside the hive and into a box, where it is connected to the extension cable.

### 3.5 Weight measurement

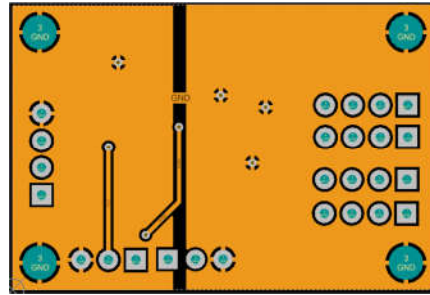
Knowing the weight of the hive is essential (among others) to determine the beginning and duration of nectar flows.

Beam-type load cells were selected because they are cheap and easy to mount. The scale can safely measure 96kg, with absolute maximum overload of 120kg. Plastic deformations occur beyond this value. To measure the output of the load cells a 24-bit sigma-delta analog to digital converter with integrated amplification is

required: AD7780. A double layer evaluation board was designed to evaluate the component (figures 3.35 and 3.36).

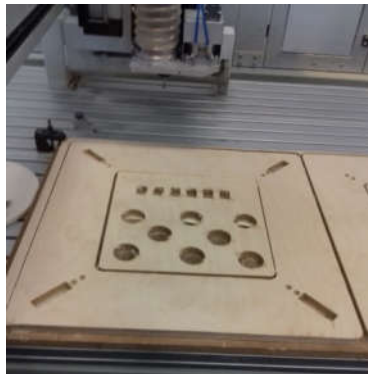


**Fig. 3.35** Evaluation board top layer.



**Fig. 3.36** Evaluation board bottom layer.

The mechanical components were built from 15mm multi-layered plywood, milled on a CNC router (figures 3.38 and 3.39). In the final step of the assembly, all components were impregnated with epoxy resin, to keep moisture away.



**Fig. 3.38** Weigh scale milling.



**Fig. 3.39** Assembled weigh scale.

The theoretical resolution, taking into account the converter noise is 3.5g, way lower than the required 100g. As a result, an accurate repeatable measurement of a 13g pencil is possible. However, all load cells have a small amount of hysteresis. For the selected ones, the average value, translated to weight, is 1kg. To reduce its influence, an equivalent graph was obtained by averaging the curve plotted when adding weights and the one plotted when removing them. Still, the result is not linear, so a two-point calibration would introduce errors. So, 8 calibration points were selected, together with Lagrange interpolation.

### 3.6 Tilt measurement

Unsupervised hives are always in danger, first because of numerous cases of theft, followed by wild animal attacks (such as bears) and strong winds.

It must be mentioned from the start that the tilt sensor development stopped at the prototype level and was never installed in a hive.

The simplest, most reliable solution is an MEMS accelerometer. MMA8452Q is a three axis accelerometer, with 12-bit resolution and low power consumption. It has three measurement ranges, I2C interface and two interrupt pins. The integration of data processing is the most powerful feature of this component. The interrupt pins are configured to wake the micro-controller when the part autonomously detects movement, free-fall, pulses or orientation changes. [11]

### 3.7 The microphone

An experienced beekeeper knows that something might be wrong with a colony just by listening it.

There is more information in the buzz frequency than in its amplitude, so the audio spectrum is required. A digital output MEMS microphone captures sound and a separate micro-controller computes the audio spectrum.

The results are not satisfying. The processor resources limit the sampling rate to 9KHz. It is enough though to validate the idea. The device is similar to the temperature sensor (figure 3.46). The microphone is protected against propolisation by a queen transport cage (figure 3.47).



**Fig. 3.46** The device, ready for a hive.

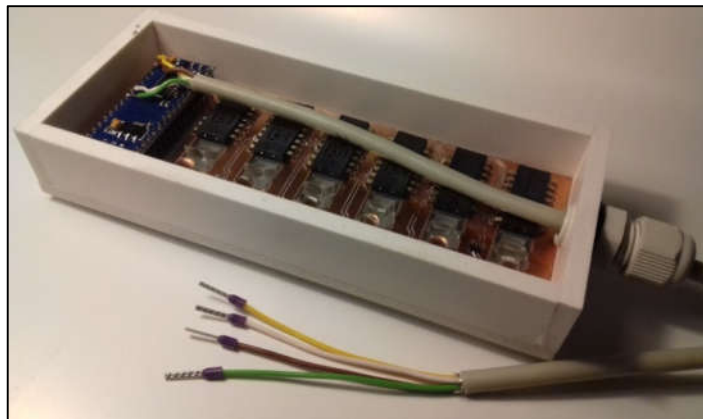


**Fig. 3.47** Microphone protection.

### 3.8 Hive entrance traffic monitoring

Colony population is currently estimated by visual inspection of the hive, but even the most skillful beekeeper will not be able to determine the exact percentage of lost bees in a day. This is especially important in areas with intense agriculture, where pesticides are often used.

The solution proposed here relies on motion transducers, used in the optical computer mice. Apart from very fine resolutions available today, the power consumption is also very low: a wireless mouse can operate up to two years with a fresh battery. The experimental device uses six sensors. The final assembly is illustrated in figure 3.57.



*Fig. 3.57* Hive entrance traffic monitoring prototype.

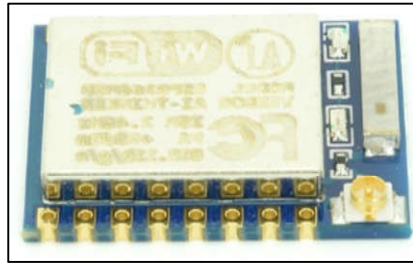
In its current form, with older generation sensors, it still consumes a lot of energy, so it was not installed on a hive. It is only a lab-tested prototype.

### 3.9 The radio module and the micro-controller

The micro-controller is the central element of the hive monitor. It holds all settings, handles the sensors and measurements and prepares them for wireless transmission. Equally important is the radio module; without it, the system would be just a simple data recorder, requiring regular data downloading.

### 3.9.1 Component selection

An ESP8266 module was selected, as it integrates in the same package a micro-controller and a radio modem, with complete WiFi stack and RF circuits. It is available as assembled module in two versions, with ceramic antenna and with PCB antenna (figures 3.62 and 3.63). The flash memory size is also different.



**Fig. 3.62** ESP8266-07 module, with antenna and external antenna connector[12].

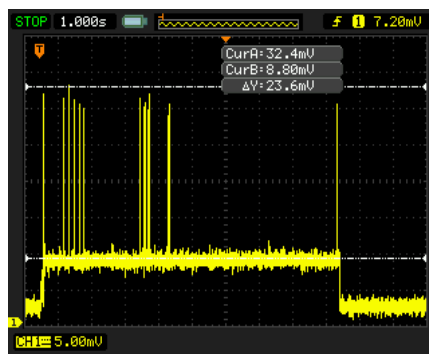


**Fig. 3.63** ESP8266-12E module with PCB antenna and 4MB flash [13].

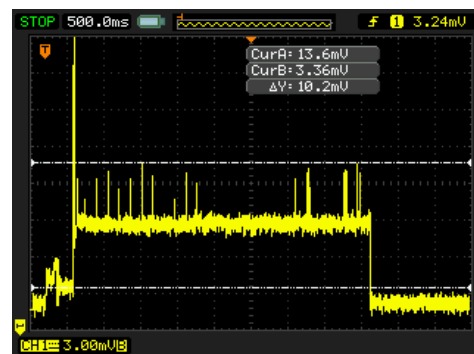
### 3.9.2 Reducing the energy consumption

The radio module was selected with flexibility in mind, so it is not the most energy efficient solution. To reduce the power consumption as much as possible, its operation must be carefully optimized. With no optimization, the power consumption is very high (figure 3.64). Several improvements are necessary: the operations order is optimized, the IP addressing is static, the WiFi channel is fixed, the sensors are powered only during reading and the transmission power is reduced for short ranges.

The result is a shorter reading and transmission cycle (from 9s to 4s), with lower current peaks (figure 3.71).



**Fig. 3.64** Module consumption, no optimization: 9s operating time.



**Fig. 3.71** Complete optimization: 4s operating time.

# Chapter 4

## The data gateway

When the hives are located in a remote apiary a way to link the local network with the mobile data network is required; this is the purpose of the gateway device. Another function is to extend the local WiFi coverage and to shorten the connection time of the hive monitors (down to 4s). A maintenance-free operation is desired, similar to the hive monitors.

### 4.1 The gateway's architecture

To ensure un-interrupted operation, the power supply and the energy storage device are critical and require careful design. The use of super-capacitors for energy storage is desired. [14]

The stored energy is converted to usable voltages for the micro-controller and modem by an efficient converter.

An ESP8266 module sits at the core of the gateway device, identical to the one used for the hive monitors.

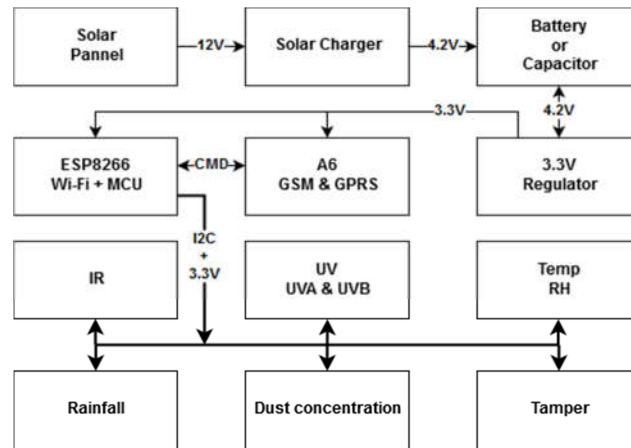
The mobile data network connection is ensured by a GSM/GPRS modem. The cheapest module in the market is A6, manufactured by A.I. Thinker. [14]

Since power, a micro-controller and a stable mechanical support are available, several environmental sensors (useful for beekeepers) will also be fitted:

- The temperature and humidity are measured by a SHT21.
- Rainfall is measured using a tilting cup rain gauge.
- Knowing the atmospheric pressure is useful as a short term forecast.
- The light sensor is useful in correlation to other parameters: humidity inside the hive with rainfall, weight and nectar flow intensity etc.
- Ultra-violet radiation might be useful for research, to observe the bees' behavior during intense radiation. [14]

Figure 4.6 illustrates a simplified block diagram of the gateway device.

The data gateway



*Fig. 4.6 Gateway block diagram [14].*

## 4.2 The power circuits

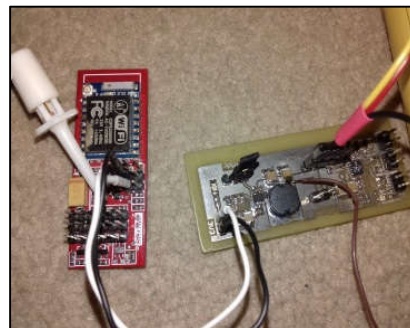
To maintain the maintenance-free principle from the hive monitors, an attempt to power the gateway with super-capacitors was made.

Two 3kF, 2.7V, 3Wh super-capacitors were available for testing. To extract as much energy as possible out of them, the 3.3V conversion method becomes very important. [14]

The experimental setup is simple: the two charged capacitors, the 3.3V regulator (several setups) and a load: the exact module used in the final circuit. The module will also record the voltage at 10-minute interval. Several conversion setups were tested: capacitors in parallel with step-up converter, in series with linear regulator, in series with step-up converter.



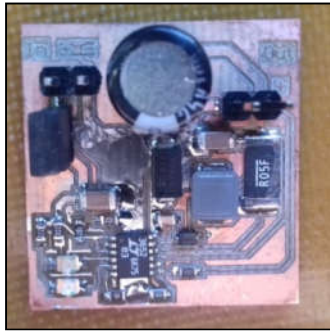
*Fig. 4.7 Two 3kF capacitors, the power converter and the load [14].*



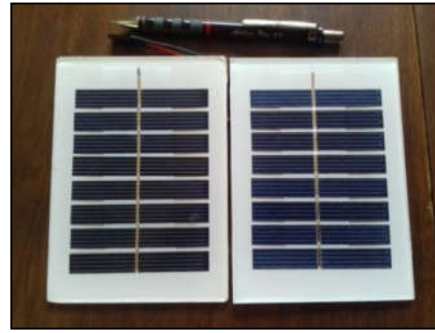
*Fig. 4.8 ESP8266 as load and recorder.[14]*



Full charge must be reached within an hour, from a solar panel, so a charger capable of delivering at least 6.4Wh is required. With a suitable solar panel, LTC3652 can deliver 8.4Wh. An evaluation PCB was designed for validation (figure 4.10). During testing, only small solar panels (0.8W) were available (figure 4.11). Two panels were connected in series to deliver 1.6Wh. [14]



**Fig. 4.10** LTC3652 test board.[14]



**Fig. 4.11** Solar panels used for charging tests.[14]

Several discharge tests were performed and the best results were obtained with series connection and a step-up converter; the longest operating time was 12 hours and 10 minutes, but that is not enough [14]. Despite their advantages, super-capacitors are not suitable for this application.



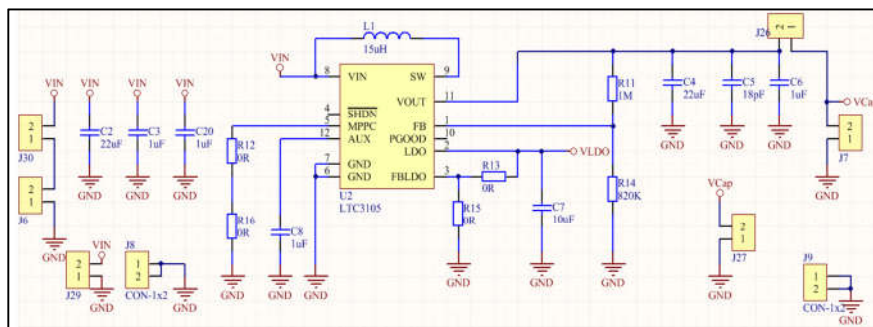
# Chapter 5

## The hive monitor experimental device

All experiments, tests and validations were performed on small, improvised blocks, connected with lots of wires. Briefly, everything was at testing level. This chapter details all steps taken to bring everything together as an easy to use and to install product, capable to withstand the elements.

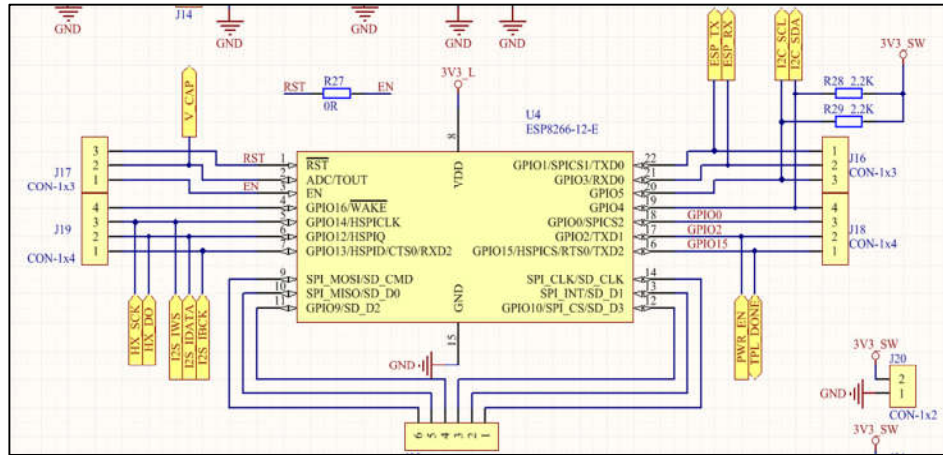
### 5.1 Electronic schematic design

The final schematic simply puts together in a single design all previously described modules. Figure 5.1 illustrates the solar charger. Energy is stored in a 400F super-capacitor, with a maximum voltage of 2.7V.



*Fig. 5.1 Solar charger electronic schematic.*

Figure 5.3 shows the modem and micro-controller module connections.



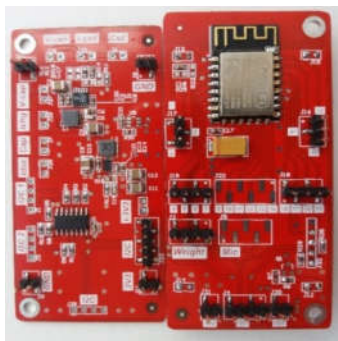
**Fig. 5.3** Modem and micro-controller module board schematic.

All module pins are broken out to vertical, 2.54mm pitch pins. There are no unconnected pins remaining. Detailed schematics are available in the complete thesis.

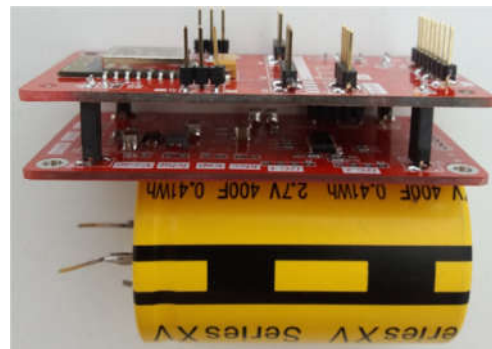
## 5.2 PCB design

After schematic validation, the PCB was designed. The result is a double-layer, square printed circuit board, with 80mm long sides (figure 5.6). The board is cut in half for stacking: the microcontroller and sensor connector board sits on top of the power board.

The assembled prototype is shown in figure 5.11. The board was assembled manually, and is displayed in figure 5.12, next to the 400F capacitor.



**Fig. 5.11** Assembled prototype.



**Fig. 5.12** The prototype, next to the capacitor.

Tests showed that several changes were required, some to address design errors, others to add features.

## 5.3 Software design

The hardware is now finished, so it is time to design a complete software version, without the work-arounds used in the tests.

Briefly, the firmware must read the data from the sensors, store them in the internal memory and send them to the gateway in a controlled manner, foreseeing and managing any errors without halting in the process. The hive monitor has two operating modes: as a recorder (data is not sent to the server, it is stored internally and the user downloads it manually) and as part of the network. The code is written in C, using the Arduino IDE, with ESP8266 plugin.

# Chapter 6

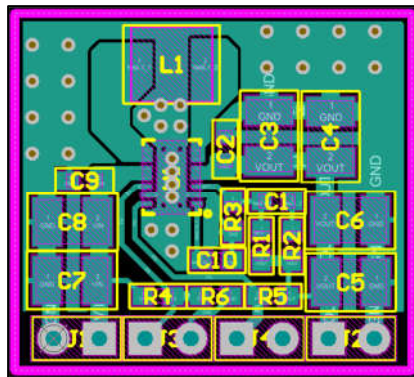
## The data gateway experimental device

Calculations and experiments showed that it is not practical to power the gateway with super-capacitors. It has been decided that Li-Ion rechargeable batteries are a better solution. An experimental device was assembled on a test board, also used for software development.

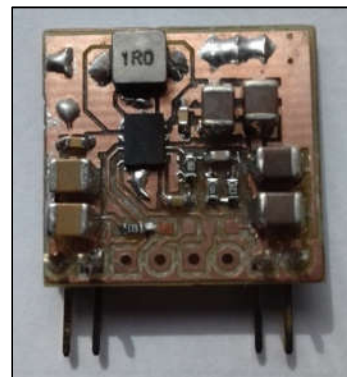
It must be mentioned from the beginning that the device remained at experimental level, un-tested in the field, but it does the job it was designed for.

### 6.1 The prototype assembly

The most important change in the design is the use of rechargeable Li-Ion batteries. Four, carefully selected cells can provide 42.18Wh, ensuring four days of uninterrupted operation, without energy from the outside (in case of solar panel failure, or total snow coverage). The battery pack is shown in figure 6.1. The assembly is protected by a plumbing fitting, enclosed with caps and grommets. A buck-boost converter was chosen to provide useful voltage and an evaluation PCB was manufactured (figure 6.4). The assembled board is illustrated in figure 6.5.



*Fig. 6.4 TPS63020 converter evaluation design.*



*Fig. 6.5 Assembled TPS63020 evaluation board.*

The data gateway experimental device

The gateway electronic assembly is made up of different modules, brought together on a universal test board, protected by a waterproof enclosure. Figure 6.6 illustrates the assembly in the enclosure.



*Fig. 6.6 Gateway circuits, in the enclosure.*

## 6.2 Software design

The firmware running on the micro-controller is similar to the one from the hive monitor, except the GSM modem management. Setup is made using any WiFi enabled device with an internet browser via a web page, just like the one from the hive monitor.

The firmware was developed using the Arduino IDE, with ESP8266 plugin. Difficulties were encountered during the GSM modem operation, especially regarding the data connection (unreliable). To obtain some usable data, the gateway was used as a WiFi repeater. The result is the reduction of hive monitor operating time, during a reading and sending cycle: from 7 seconds to 4-5 seconds.

## 6.3 The storage and display server

A new storage and display server was created. The data reception part (the actual server) was created using Node-Red, running on a Raspberry Pi platform, for low power consumption.

A time-based database was selected for data storage, ideal for IoT applications: InfluxDB.

The Grafana display and analysis engine is used for flexible, intuitive and user-friendly interface (figure 6.11).



*Fig. 6.11 Software for data reception, storage and display.[15,16,17]*

# Chapter 7

## The prototype assembly and hive installation

It has been a long way from the first tests to the delivery of a completely functional hive monitor, especially because of the software component, which had to be brought to an easy to use, esthetic shape.

The final assembly is shown in figure 7.7. The entire hive monitor takes very little space, its presence being betrayed by the solar panel.



*Fig. 7.7* Hive on the scale.



*Fig. 7.8* Temperature sensor, between the hive bottom and the box.

After charging and the final check-up, the monitor was delivered to a beekeeper for long-term tests and fitted under a hive in Băldana, on July 13-th, 2018. Figure 7.11 illustrates the monitor installed under the hive.

The monitor was checked again towards winter's end (February 14, 2019), and the moisture took its toll on the plywood. It appears that the resin was not evenly spread and small pores remained exposed (figures 7.13 and 7.14).



**Fig. 7.13** Monitored hive, at winter's end.



**Fig. 7.14** Detail: insufficiently protected plywood.

A serious assembly problem now affects the load cells: it appears that the screw holes were not well covered in resin and the moisture affected the areas of maximum stress in the whole structure.



# Chapter 8

## Conclusions

Intermediary data and results were available from the first lines of code and the first assembled modules, as ugly prototypes with gross (but functional) improvisations. But the most valuable data started pouring after the delivery and setup of the prototype from under the hive. All of these are detailed in the complete thesis.

### 8.1 Original contributions

Chapter 2:

1. Several professional beekeepers were consulted, together with the PhD supervisor. This is how the exact requirements of the hive monitoring system were established.
2. The sensor structure required to monitor a honeybee hive was established, also detailed in paper [4].
3. I researched intensively the area of beekeeping, to be able to maintain a few colonies for tests and firsthand experience, to understand the activity of a beekeeper.

Chapter 3:

1. I established the system architecture, based on data from the beekeepers and on individual research. Its components are detailed in all published papers, in various stages of design and test [2], [3], [4], [5] and [6].
2. I established the hive monitor power circuit architecture, as published in paper [3]. I decided to use of a super-capacitor as energy storage device, taking into account the results exposed in paper [2]. From all solutions available on the market, I selected the optimal one, capable of extracting the most energy from the super-capacitor: low operating voltage, low quiescent current and high efficiency.

3. I performed circuit simulations of the solar charger and the step-up converter, as used in the hive monitor. The results are published in paper [3].
4. I manufactured a power circuit prototype, shown in [3]. Practical experiments with solar cells, their assembly as solar panels and some tests are also illustrated in [3].
5. Also, publication [3] holds results of long term charging tests, especially in the cold season, with short days and low available power.
6. I solved the step-up converter low voltage start-up issue. It was noticed after article publication, so the solution was not published.
7. I selected and implemented the sensor structure digital bus, explained in detail in publication [4].
8. I selected the temperature and humidity sensor and I built a printed circuit board to be installed inside the hive. I also designed and built several wooden enclosures to protect the sensor against propolisation. Design steps are illustrated in [4].
9. I selected a weight measurement solution. This includes the scale's performance, the force transducers and the analog-to-digital converter. I designed the schematic, the PCB and I built a prototype to test the converter.
10. I designed and built the mechanical elements of the scale, also used to support the rest of the monitor's elements. I illustrated the low quality of the load cells, by exposing the amount of hysteresis when adding and removing weights.
11. I implemented a way to reduce the influence of hysteresis, using an equivalent curve and cutting the hysteresis errors in half.
12. I implemented a calibration method using polynomial interpolation, to reduce the load cell non-linearity errors. The resulting resolution is 10 times finer than the initial requirement.
13. I made a short comparative analysis of the hive sound for a normal colony and a swarming colony, detailing the differences in the audio spectrum. I built the experimental model, including the hardware and software parts to record the sound and to obtain the spectrum, but with little satisfaction. It validates the idea, though.
14. I worked around the disadvantages of the classic bee counting mechanisms by using an original solution, comprised of optical mouse sensors; they are cheap,

precise and low power. I built a prototype, ready to be assembled on a hive and tested it in the lab.

15. I selected the components that provide the monitor's computing power and the ability to send the data. The two are also shown in publications [4] and [5]. I made several experiments to reduce the power consumption, mainly by reducing the time it takes to read the sensors and to send the data via radio.

#### Chapter 4:

1. I established the gateway architecture and sensor structure, both detailed in publication [4]. The powering circuit is strongly emphasized.
2. Originally, the gateway was intended to be powered by super-capacitors, to obtain a reliable, long-term power solution, but all experiments showed that this option is too expensive and too bulky to fit the application.
3. I decided to use Li-Ion rechargeable batteries, protected from sub-zero temperatures by burying them underground. Also, a power budget and a solar charging solution are detailed here (and in [4]). I developed an evaluation board, that was professionally manufactured later. Multiple charge and discharge tests were performed, with super-capacitors and with Li-Ion and Li-FePO batteries.

#### Chapter 5

1. I calculated and designed the final schematics for the hive monitor, ready to be professionally manufactured: the charger, the step-up converter, the micro-controller and all auxiliary circuits. As backup, I also installed an ultra-low power timer for enabling the step-up converter, in case the power consumption in sleep mode was too high.
2. I designed the PCB, according to the electrical and the mechanical constraints, imposed by the enclosure. By manufacturing the PCB to be separated in half and to be stacked, I optimized the fabrication costs. The boards are fully functional in the original state too, without separation. Publication [4] holds the details.
3. I built the startup-on-request circuit, without additional power consumption and without exposing mechanical elements through the enclosure.

4. I addressed the PCB errors.
5. I assembled and tested the entire hive monitor, with solar panel, weigh scale, temperature and humidity sensors and moisture insulation.
6. I selected an optimal programming solution, with the development environment and the programming language. I developed the software component, using both original elements and external libraries. The result is a robust firmware, capable of dealing with errors without halting, keeping in mind all constraints, especially the energy-related ones.
7. I also built a simple, easy to use graphical interface, capable of running on any internet browser, on any WiFi enabled device.

#### Chapter 6:

1. I selected the energy storage solutions for the gateway and I implemented one of them, capable of powering the device for four days with no outside energy input. The initial request was for three days.
2. I selected a flexible buck-boost regulator, capable of outputting a fixed voltage, whether the input is higher or lower than the output. I designed the electronic schematic and built a test board. I made the final assembly containing the solar charger, the buck-boost converter, the micro-controller and the GSM modem in a weather-proof enclosure, ready to use.
3. I designed the mechanical part of the gateway and a cheap solar radiation shield, that ensures precise air temperature measurement with little influence from the sun. The shield works by creating a natural airflow in the space between two coaxial pipes, which draws fresh air inside the internal pipe. A smaller prototype was tested for a long time with a hive monitor, used as a weather station.
4. I implemented the gateway firmware with partial success. The software is similar to the one from the hive monitor, running on the same platform, and contains the same error management features. It offers a simple graphical interface (a web page) and has two operating modes: as WiFi repeater and as GSM-WiFi translator. The first mode was successfully implemented and proved itself useful by reducing the hive monitor connection time and saving

power. The second mode was not implemented due to software development and error management difficulties.

5. I implemented a robust data storage and display server using a group of free software. The server is built in Node-Red, data is stored in an InfluxDB database and a dedicated display and analysis engine provides a professional interface. This way, all disadvantages and limitations of the first server (a free version of a commercial service) were eliminated.

#### Chapter 7:

1. I assembled and I brought the hive monitor to a ready-to-deliver state.
2. I obtained useful data from a hive, during an entire beekeeping year.

## 8.2 Original publications list

1. Scientific papers, published and indexed in scientific events' volumes (ISSI) and Web Of Science (WOS):
  1. **M. Vidrașcu, M. Vlădescu**, *Programmable pulsed current driver for high power LEDs applications*, 2014 IEEE 20th International Symposium for Design and Technology in Electronic Packaging (SIITME), Bucharest, 2014, pp. 123-127, DOI 10.1109/SIITME.2014.6967008, WOS:000358258300020.
  2. **M. Vidrașcu, P. Svasta**, *The influence of charging/discharging current on supercapacitor's storage capacity*, 2015 IEEE 21st International Symposium for Design and Technology in Electronic Packaging (SIITME), Brasov, 2015, pp. 181-186, DOI 10.1109/SIITME.2015.7342321, WOS: 000377765500033.
  3. **M. Vidrașcu, P. Svasta, M. Vlădescu**, *Maintenance-free supercapacitor-based WSN power supply*, Proc. SPIE 10010, Advanced Topics in Optoelectronics, Microelectronics, and Nanotechnologies VIII (ATOM), Constanța 2016, DOI 10.1117/12.2246114, WOS:000391359600051
  4. **M. Vidrașcu, P. Svasta, M. Vlădescu**, *High reliability wireless sensor node for bee hive monitoring*, 2016 IEEE 22nd International Symposium for Design and Technology in Electronic Packaging (SIITME), Oradea,

2016, pp. 134-138, DOI 10.1109/SIITME.2016.7777262,  
WOS:000390557400027.

5. **M. Vidrașcu, P. Svasta**, *Embedded software for IOT bee hive monitoring node*, 2017 IEEE 23rd International Symposium for Design and Technology in Electronic Packaging (*SIITME*), Constanta, 2017, pp. 183-188; DOI 10.1109/SIITME.2017.8259887, WOS:000428032300038.
6. **M. Vidrașcu and P. Svasta**, *Maintenance-free IOT gateway design for bee hive monitoring*, 2017 IEEE 23rd International Symposium for Design and Technology in Electronic Packaging (*SIITME*), Constanta, 2017, pp. 189-193, DOI 10.1109/SIITME.2017.8259886, WOS:000428032300037.

2. Research reports, during the PhD studies:

1. **M. Vidrașcu**, *Sistem IoT de monitorizare a familiei de albine*, Scientific Report, nr. 1, June, 2015.
2. **M. Vidrașcu**, *Concentrator de date Iot pentru monitorizarea familiei de albine*, Scientific Report, nr. 2, December, 2015.
3. **M. Vidrașcu**, *Sursă de alimentare pentru noduri de rețele de senzori wireless folosind super-condensatoare*, Scientific Report, nr. 3, June, 2016.
4. **M. Vidrașcu**, *Structură de senzori pentru monitorizarea activității albinelor*, Scientific Report, nr. 4, December, 2016.
5. **M. Vidrașcu**, *Software Iot pentru monitorizarea familiei de albine*, Scientific Report, nr. 5, June, 2017.

3. Papers accepted for publishing:

1. **M. Vidrașcu**, *Sistem de monitorizare a familiilor de albine*, UPB Scientific Bulletin, article accepted for publishing, identifier 8949.

# Bibliography

- [1] **E. Căuia, A. Siceanu**, *Albina – Sensor al mediului. Echipament electronic pentru monitorizarea unor procese biologice din familia de albine și mediul ambiant*, device description, S.C. Institutul de cercetare dezvoltare pentru apicultura S.A., 2014.
- [2] **I. Barac, E. Mârza, N. Nicolaide, M. Șerban, E. Tarța**, *Manualul Apicultorului*, Edition 6, Beekeepers' Association of Romania, 2016.
- [3] **L. Ospătaru, V. Alexandru, P. Bucată, V. GH. Dan, N. Nicolaide, TR. Volcinski**, *Tehnologia creșterii și exploatării albinelor*”, agroindustrial highschoools handbook, beekeeping department, Beekeeping Publishing Group, Bucharest, 1981.
- [4] **K. Rose, S. Eldridge, L. Chapin**, *The Internet of Things: An overview*, The Internet Society, 2015.
- [5] **M. Vidrașcu**, *The influence of charging/discharging current on supercapacitor's storage capacity*, IEEE 21st International Symposium for Design and Technology in Electronic Packaging (SIITME), Romania, Brașov, 2015.
- [6] **M. Vidrașcu, P. Svasta, M. Vlădescu**, *High Reliability Wireless Sensor Node for Bee Hive Monitoring*, IEEE 22nd International Symposium for Design and Technology in Electronic Packaging (SIITME), pp. 134-138, Romania, Oradea, 2016.
- [7] **M. Vidrașcu**, *Sursa de alimentare pentru noduri de rețele de senzori wireless folosind super-condensatoare*, PhD report, nr 3, June 2016.
- [8] \*\*\*, *LTC3105 400mA Step-Up DC/DC Converter with Maximum Power Point Control and 250mV Start-Up*, Linear Technologies Corporation, component datasheet, 2010.
- [9] \*\*\*, *LTC3539/LTC3539-2 2A, 1MHz/2MHz Synchronous Step-Up DC/DC Converters*, Linear Technologies Corporation, component datasheet, 2008.
- [10] \*\*\*, *SHT21 Humidity and temperature sensor IC*, component datasheet, Sensirion, May 2014.
- [11] \*\*\*, *MMA8452Q 3-Axis, 12-bit/8-bit Digital Accelerometer*, FreeScale Semiconductor, component datasheet, 2014.
- [12] [https://www.banggood.com/ESP8266-ESP-07-Remote-Serial-Port-WIFI-Transceiver-Wireless-Module-p-961247.html?cur\\_warehouse=CN](https://www.banggood.com/ESP8266-ESP-07-Remote-Serial-Port-WIFI-Transceiver-Wireless-Module-p-961247.html?cur_warehouse=CN), accessed on 13.09.2019.
- [13] <https://www.optimusdigital.ro/ro/wireless-wifi/78-modul-wifi-esp-12.html>, accessed on 01.09.2019.
- [14] **M. Vidrașcu**, *Concentrator de date IoT pentru monitorizarea familiei de albine*, PhD Report, nr. 2, December 2015.
- [15] [www.grafana.com](http://www.grafana.com), accessed on 13.09.2019.
- [16] <https://en.wikipedia.org/wiki/Node-RED>, accessed on 13.09.2019.
- [17] <https://www.influxdata.com/>, accessed on 13.09.2019.